

JETBOIL
SUMO

(EN) ENGLISH
(FR) FRANÇAIS
(DE) DEUTSCH
(ES) ESPAÑOL
(IT) ITALIANO
(NL) NEDERLANDS
(DK) DANISH
(FI) FINNISH

Important: Read these instructions for use carefully. Familiarize yourself with the location of the control buttons on the stove. Observe the reference use OUTDOORS only.

FOR YOUR SAFETY

If you smell gas:

- Do not attempt to light appliance.
- Do not touch any open flame.
- Disconnect from fuel supply.
- Do not store or use gasoline or any other liquids with flammable vapors in the vicinity of this or any other appliance.

CARBON MONOXIDE HAZARD

DANGER
This appliance can produce carbon monoxide which has no odor.
Never use it in an enclosed space can kill you.
Using this appliance in an enclosed space may result in carbon monoxide poisoning, coma or death.

Specifications:
Use capacity: 1.5 liter
Fuel: 1. Butane
2. Propane
3. Isobutane
4. Gas pressure: 11.5 bar
5. Gas pressure: 11.5 bar
6. Gas pressure: 11.5 bar
7. Gas pressure: 11.5 bar
8. Gas pressure: 11.5 bar
9. Gas pressure: 11.5 bar
10. Gas pressure: 11.5 bar

(FR) FRANÇAIS

Important: Lire attentivement ces instructions d'utilisation. Familiarisez-vous avec l'emplacement des boutons de commande de la cuisinière. Observez attentivement les instructions pour l'utilisation en extérieur.

IMPORTANT

Si vous sentez une odeur de gaz:

- N'essayez pas d'allumer l'appareil.
- N'évitez pas de toucher la flamme.
- Déconnectez de l'alimentation en gaz.
- N'entassez pas ou n'utilisez pas d'essence ou d'autres liquides à vapeurs inflammables près de cet appareil ou de tout autre appareil.

DANGER
Cet appareil peut produire du monoxyde de carbone, un gaz inodore.
N'utilisez jamais cet appareil dans un espace fermé comme un camping-car, une tente, une voiture ou une résidence.

Spécifications:
Capacité d'utilisation: 1,5 litre
Carburant: 1. Butane
2. Propane
3. Isobutane
4. Pression de gaz: 11,5 bar
5. Pression de gaz: 11,5 bar
6. Pression de gaz: 11,5 bar
7. Pression de gaz: 11,5 bar
8. Pression de gaz: 11,5 bar
9. Pression de gaz: 11,5 bar
10. Pression de gaz: 11,5 bar

(DE) DEUTSCH

Wichtig: Lesen Sie sich diese Gebrauchsanleitung sorgfältig durch. Machen Sie sich mit der Position der Bedienelemente der Abwehler- angeschlossen. Beachten Sie diese Gebrauchsanleitung für den sicheren Verwendungsort.

Wichtig: Lesen Sie sich diese Gebrauchsanleitung sorgfältig durch. Machen Sie sich mit der Position der Bedienelemente der Abwehler- angeschlossen. Beachten Sie diese Gebrauchsanleitung für den sicheren Verwendungsort.

Wichtig: Lesen Sie sich diese Gebrauchsanleitung sorgfältig durch. Machen Sie sich mit der Position der Bedienelemente der Abwehler- angeschlossen. Beachten Sie diese Gebrauchsanleitung für den sicheren Verwendungsort.

Wichtig: Lesen Sie sich diese Gebrauchsanleitung sorgfältig durch. Machen Sie sich mit der Position der Bedienelemente der Abwehler- angeschlossen. Beachten Sie diese Gebrauchsanleitung für den sicheren Verwendungsort.

Wichtig: Lesen Sie sich diese Gebrauchsanleitung sorgfältig durch. Machen Sie sich mit der Position der Bedienelemente der Abwehler- angeschlossen. Beachten Sie diese Gebrauchsanleitung für den sicheren Verwendungsort.

(ES) ESPAÑOL

Importante: Leer atentamente estas instrucciones de uso. Familiarizarse con la posición de los botones de control de la estufa. Observar cuidadosamente las instrucciones para referencias AUSE EN EL ALRE LIBRE.

Importante: Leer atentamente estas instrucciones de uso. Familiarizarse con la posición de los botones de control de la estufa. Observar cuidadosamente las instrucciones para referencias AUSE EN EL ALRE LIBRE.

Importante: Leer atentamente estas instrucciones de uso. Familiarizarse con la posición de los botones de control de la estufa. Observar cuidadosamente las instrucciones para referencias AUSE EN EL ALRE LIBRE.

Importante: Leer atentamente estas instrucciones de uso. Familiarizarse con la posición de los botones de control de la estufa. Observar cuidadosamente las instrucciones para referencias AUSE EN EL ALRE LIBRE.

Importante: Leer atentamente estas instrucciones de uso. Familiarizarse con la posición de los botones de control de la estufa. Observar cuidadosamente las instrucciones para referencias AUSE EN EL ALRE LIBRE.

(IT) ITALIANO

Importante: Leggere attentamente le istruzioni d'uso. Familiarizzarsi con la posizione dei pulsanti di controllo della stufa. Osservare con attenzione le istruzioni per l'uso all'aperto.

Importante: Leggere attentamente le istruzioni d'uso. Familiarizzarsi con la posizione dei pulsanti di controllo della stufa. Osservare con attenzione le istruzioni per l'uso all'aperto.

Importante: Leggere attentamente le istruzioni d'uso. Familiarizzarsi con la posizione dei pulsanti di controllo della stufa. Osservare con attenzione le istruzioni per l'uso all'aperto.

Importante: Leggere attentamente le istruzioni d'uso. Familiarizzarsi con la posizione dei pulsanti di controllo della stufa. Osservare con attenzione le istruzioni per l'uso all'aperto.

Importante: Leggere attentamente le istruzioni d'uso. Familiarizzarsi con la posizione dei pulsanti di controllo della stufa. Osservare con attenzione le istruzioni per l'uso all'aperto.

(NL) NEDERLANDS

Belangrijk: Lees deze gebruiksaanwijzing zorgvuldig. Maak u kennis met de positie van de bedieningsknoppen op de stov. Observeer aandachtig de aanwijzingen voor gebruik buitenshuis.

Belangrijk: Lees deze gebruiksaanwijzing zorgvuldig. Maak u kennis met de positie van de bedieningsknoppen op de stov. Observeer aandachtig de aanwijzingen voor gebruik buitenshuis.

Belangrijk: Lees deze gebruiksaanwijzing zorgvuldig. Maak u kennis met de positie van de bedieningsknoppen op de stov. Observeer aandachtig de aanwijzingen voor gebruik buitenshuis.

Belangrijk: Lees deze gebruiksaanwijzing zorgvuldig. Maak u kennis met de positie van de bedieningsknoppen op de stov. Observeer aandachtig de aanwijzingen voor gebruik buitenshuis.

Belangrijk: Lees deze gebruiksaanwijzing zorgvuldig. Maak u kennis met de positie van de bedieningsknoppen op de stov. Observeer aandachtig de aanwijzingen voor gebruik buitenshuis.

(DK) DANISH

Vigtigt: Læs denne vejledning omhyggeligt. Gør dig fortrolig med enheden. Overvåg omhyggeligt de anvisninger om brug udenfor.

Vigtigt: Læs denne vejledning omhyggeligt. Gør dig fortrolig med enheden. Overvåg omhyggeligt de anvisninger om brug udenfor.

Vigtigt: Læs denne vejledning omhyggeligt. Gør dig fortrolig med enheden. Overvåg omhyggeligt de anvisninger om brug udenfor.

Vigtigt: Læs denne vejledning omhyggeligt. Gør dig fortrolig med enheden. Overvåg omhyggeligt de anvisninger om brug udenfor.

Vigtigt: Læs denne vejledning omhyggeligt. Gør dig fortrolig med enheden. Overvåg omhyggeligt de anvisninger om brug udenfor.

(FI) FINNISH

Tärkeää: Enkä näin ollen huolellisesti lue käyttöohjeita. Tutustu huolellisesti yksittäisten ohjeiden sijaintiin. Huomaa erityisesti ohjeet käytöstä ulkona.

Tärkeää: Enkä näin ollen huolellisesti lue käyttöohjeita. Tutustu huolellisesti yksittäisten ohjeiden sijaintiin. Huomaa erityisesti ohjeet käytöstä ulkona.

Tärkeää: Enkä näin ollen huolellisesti lue käyttöohjeita. Tutustu huolellisesti yksittäisten ohjeiden sijaintiin. Huomaa erityisesti ohjeet käytöstä ulkona.

Tärkeää: Enkä näin ollen huolellisesti lue käyttöohjeita. Tutustu huolellisesti yksittäisten ohjeiden sijaintiin. Huomaa erityisesti ohjeet käytöstä ulkona.

Tärkeää: Enkä näin ollen huolellisesti lue käyttöohjeita. Tutustu huolellisesti yksittäisten ohjeiden sijaintiin. Huomaa erityisesti ohjeet käytöstä ulkona.

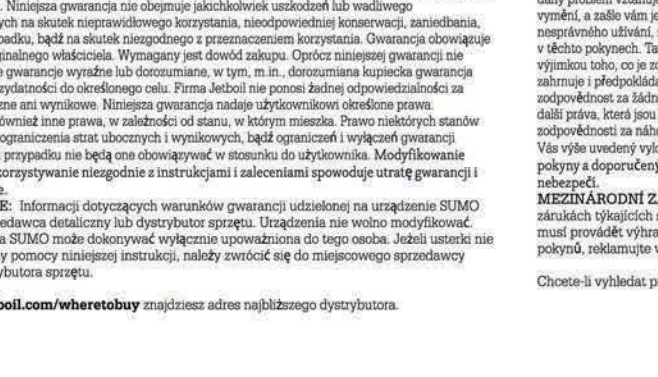
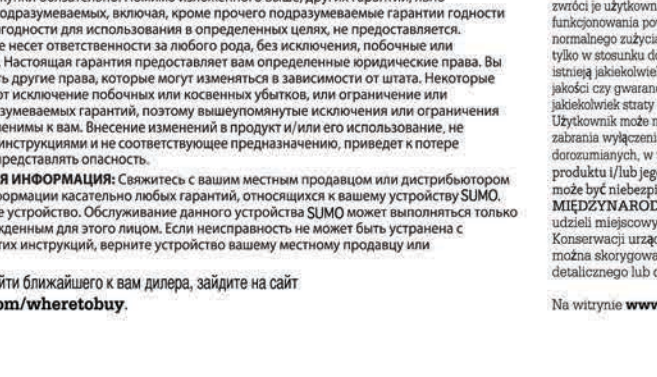
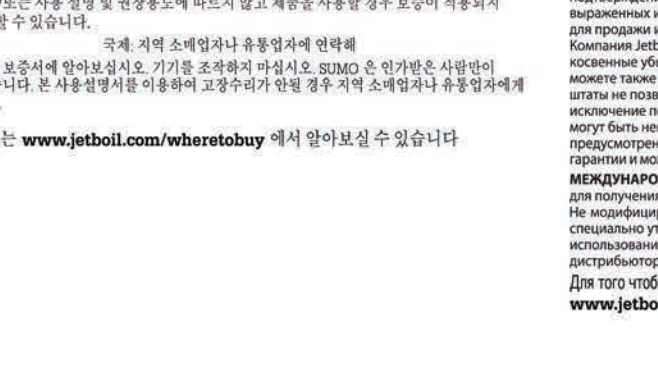
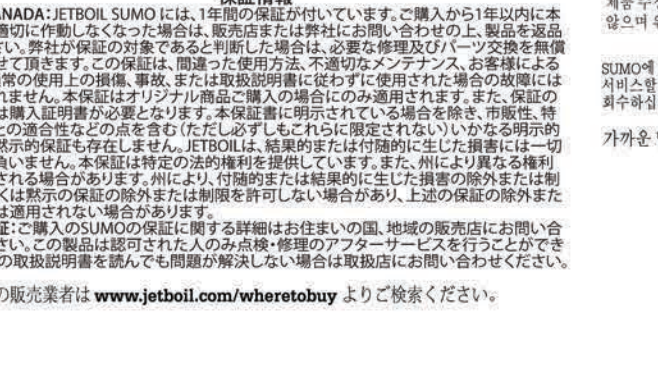
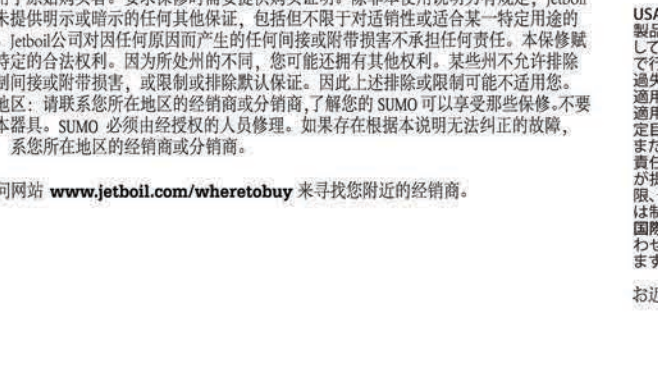
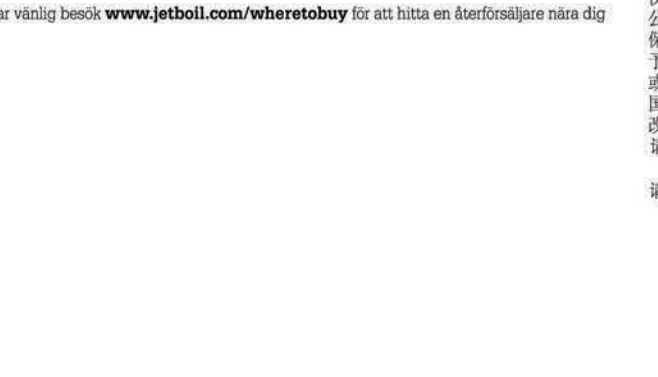
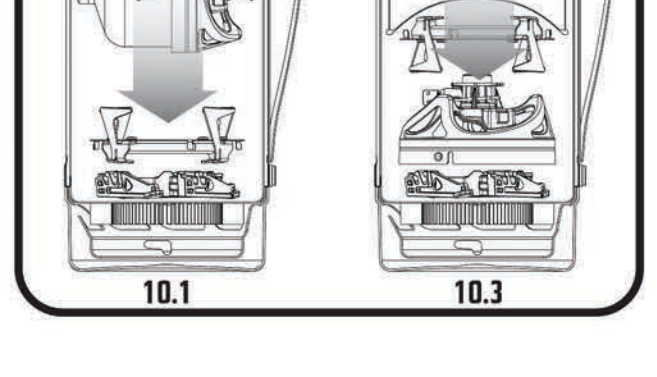
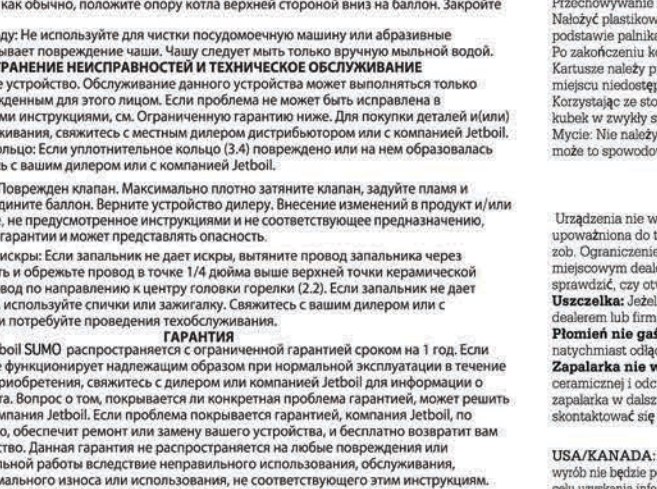
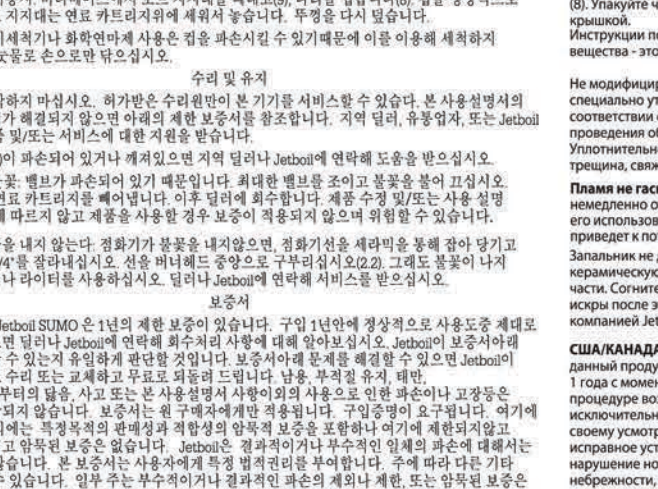
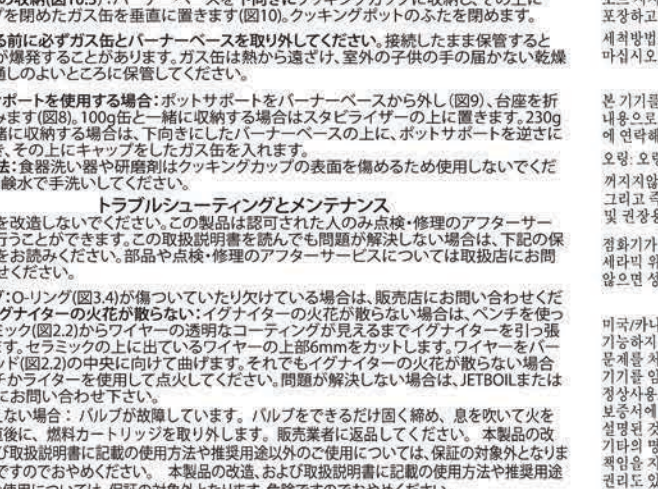
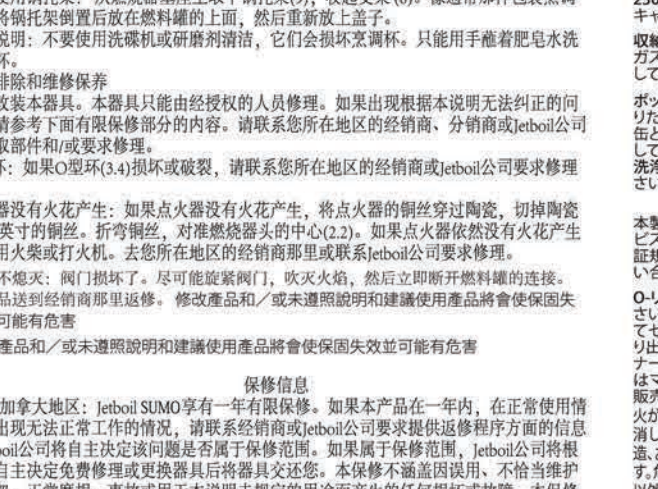
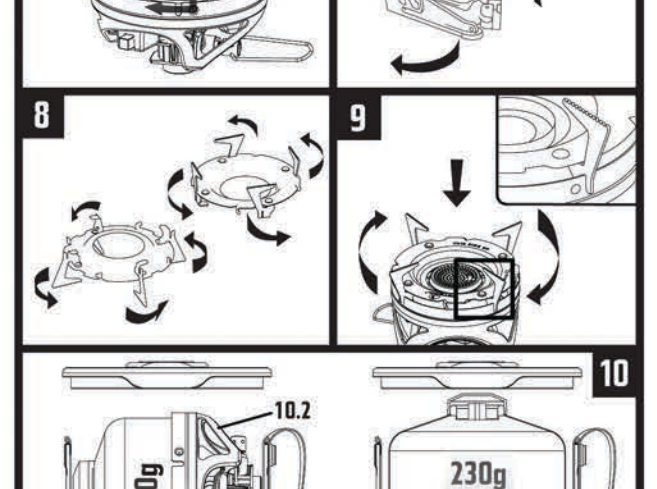
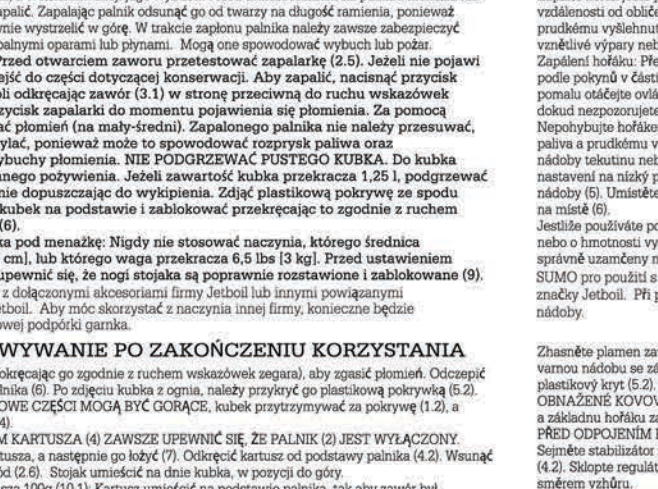
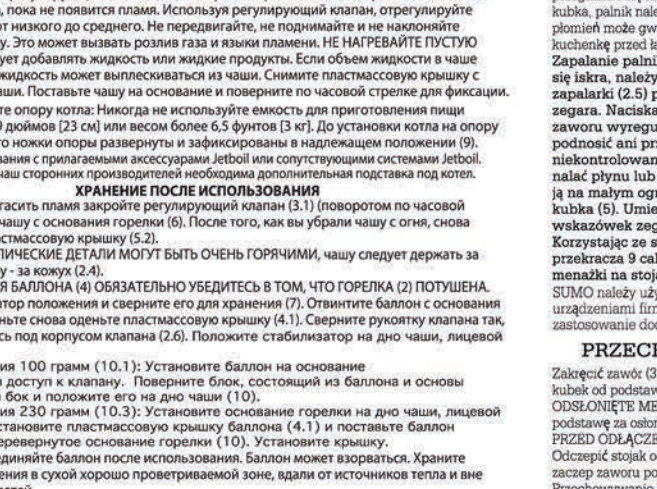
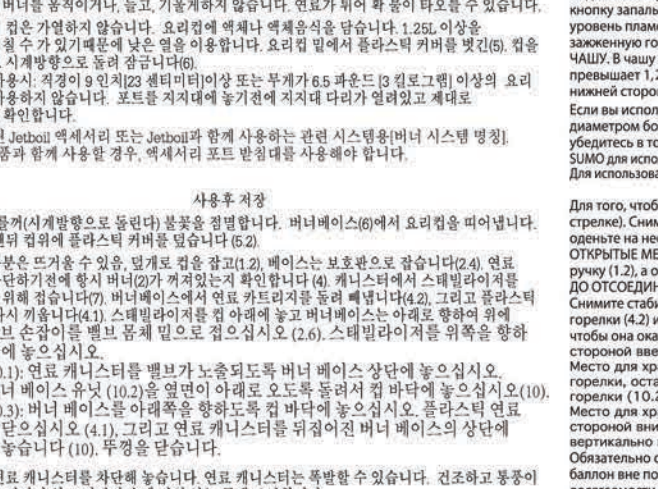
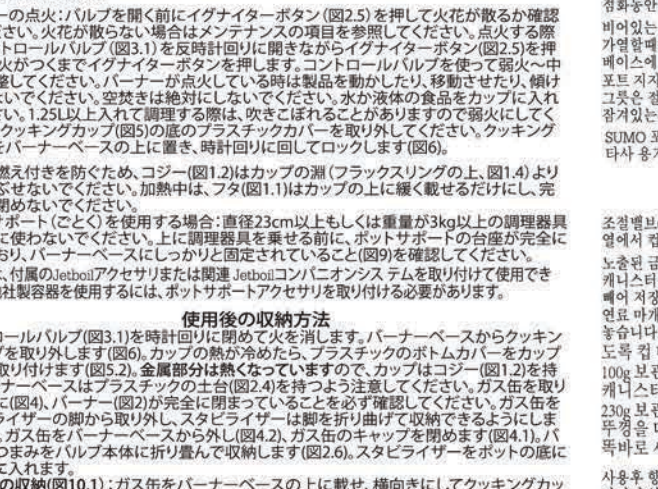
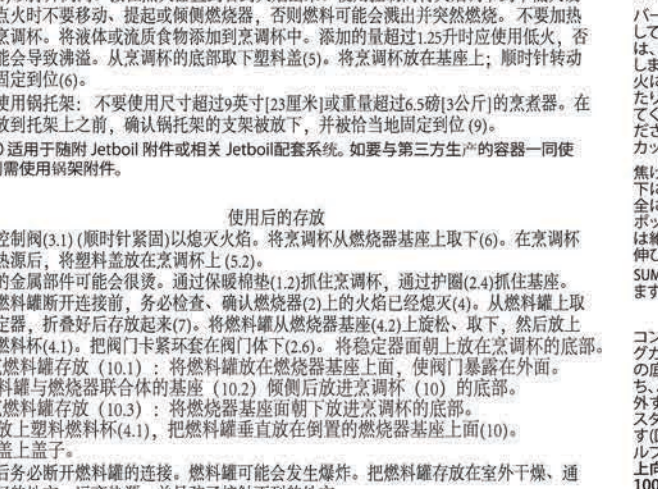
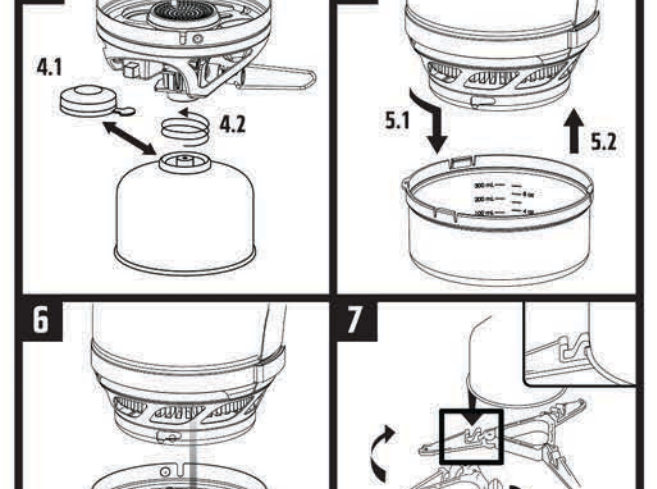
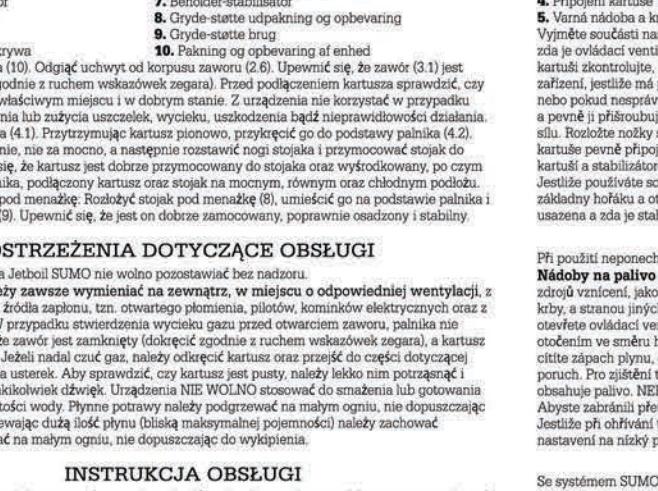
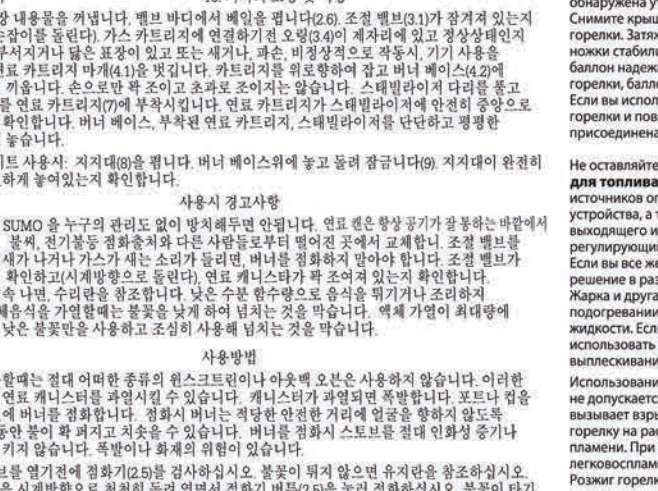
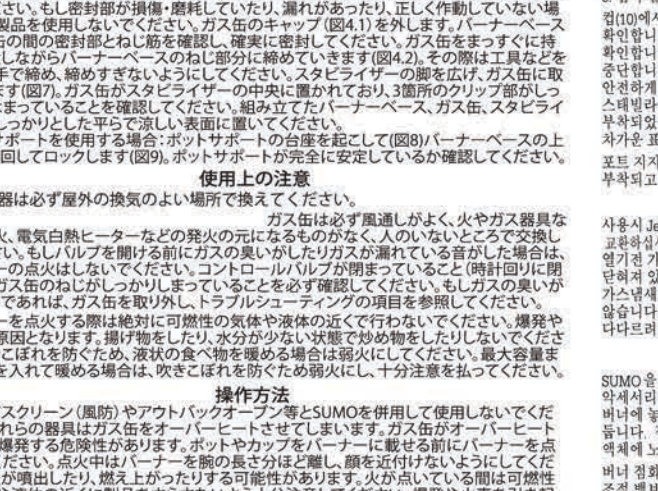
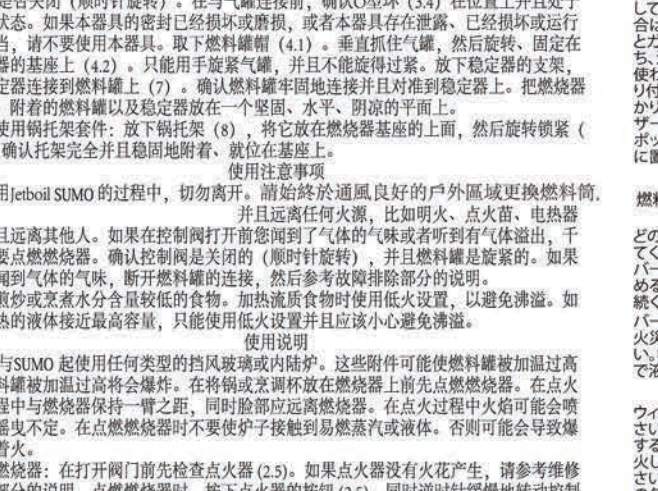
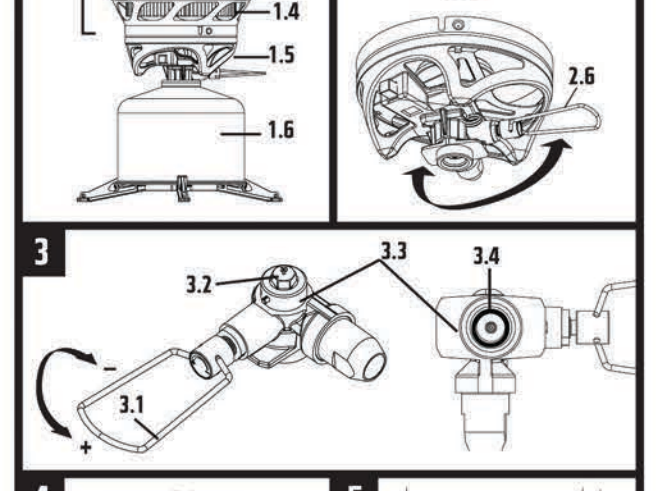
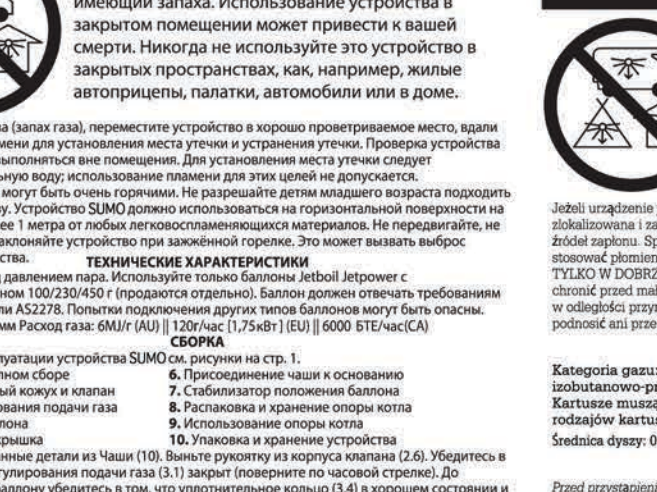
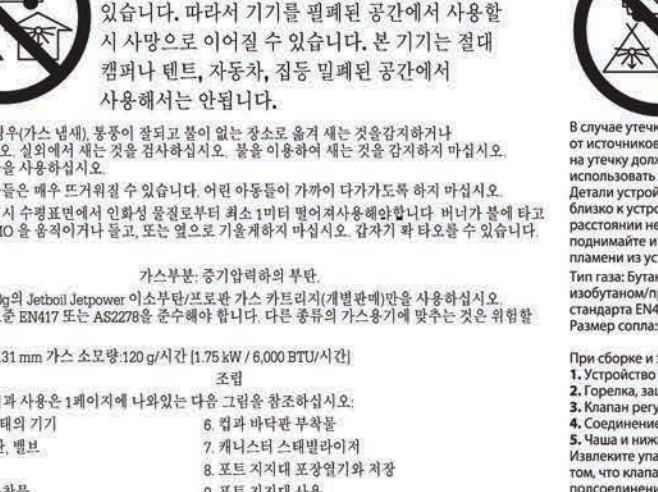
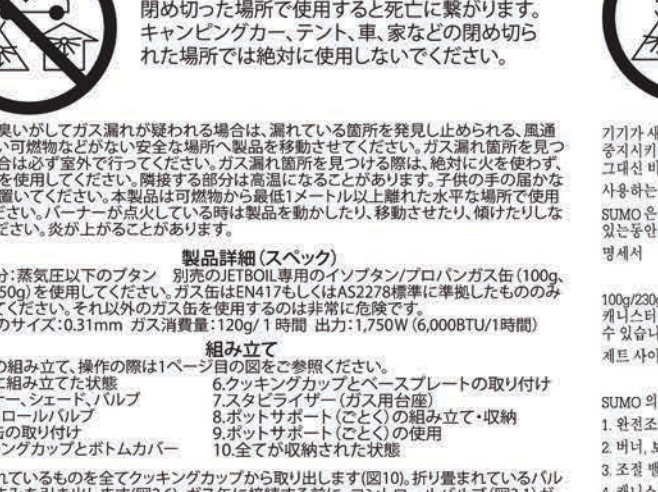
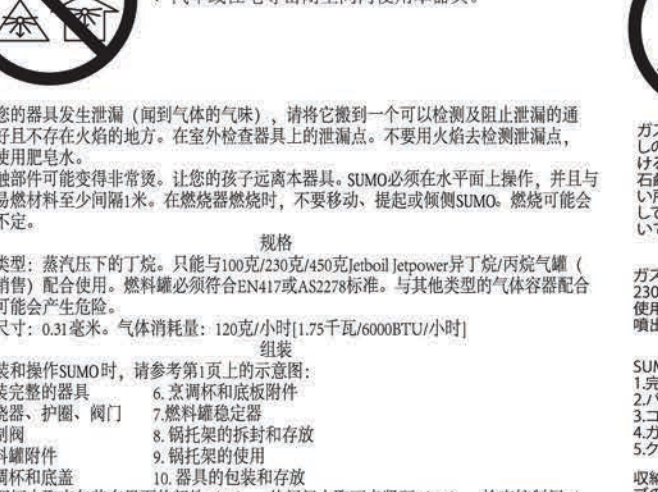
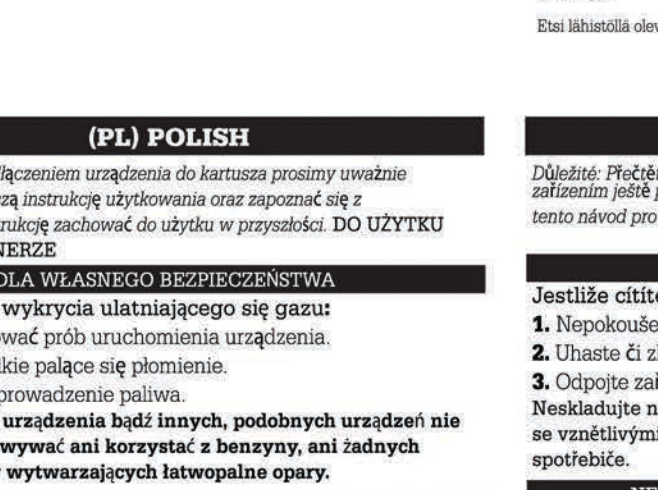
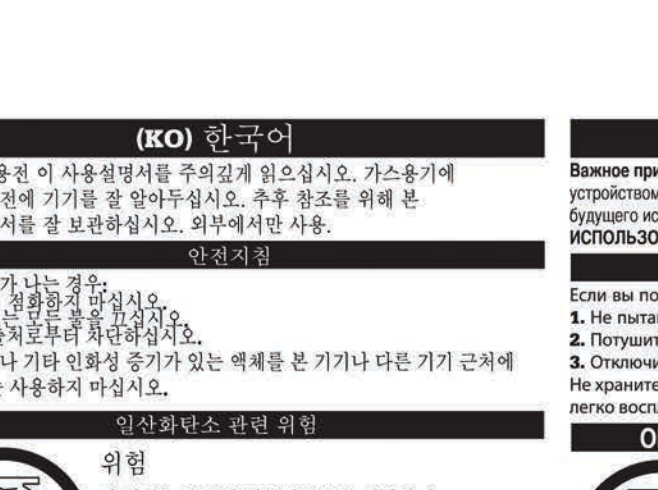
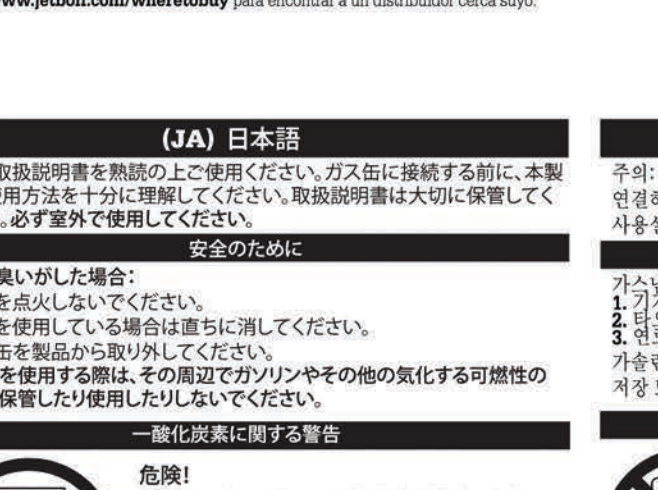
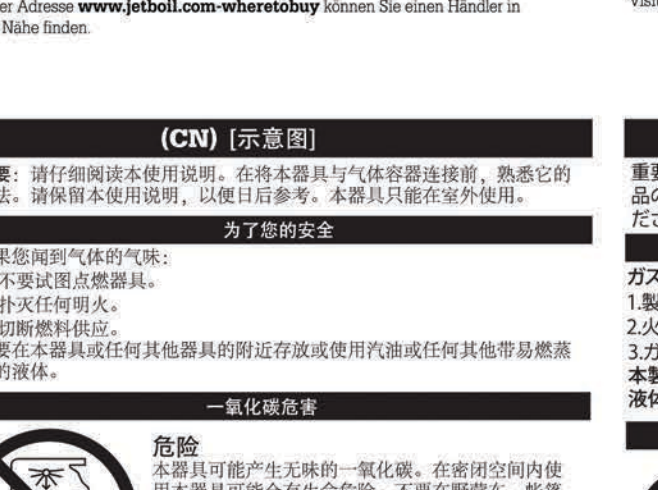
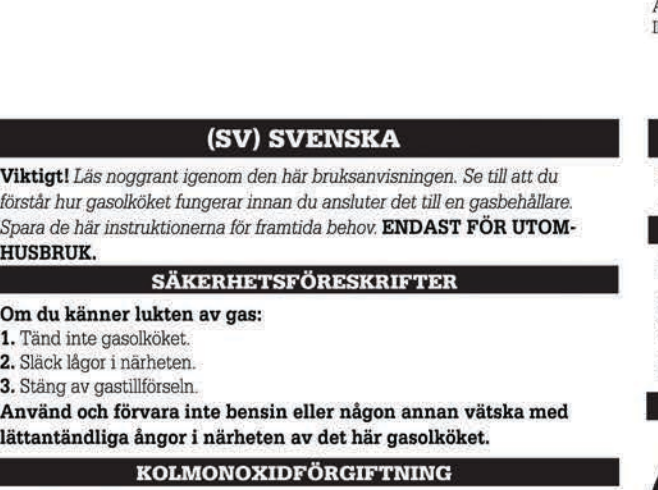
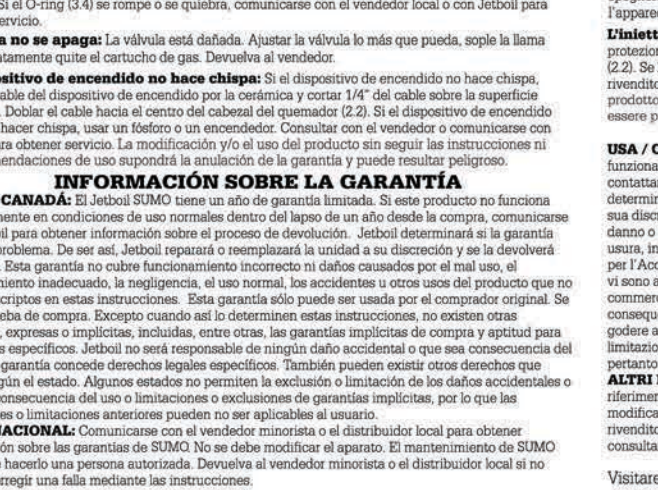
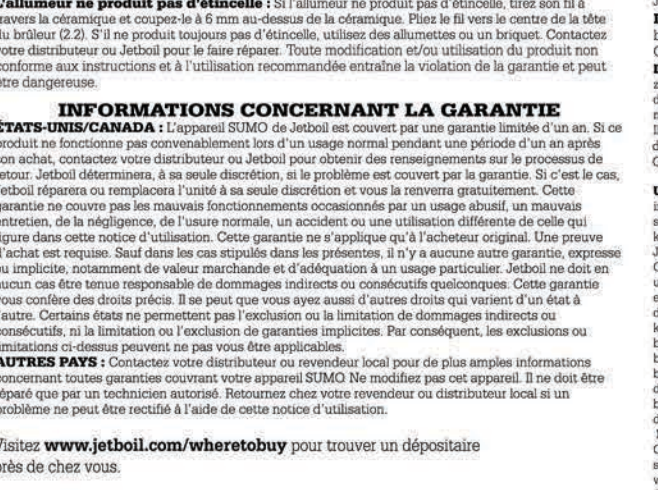
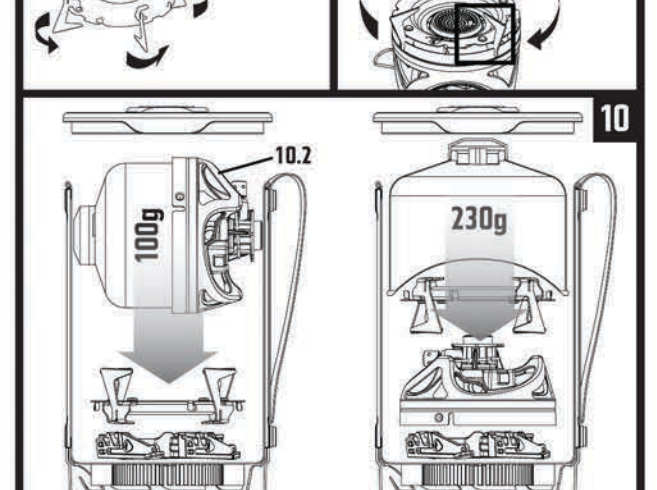
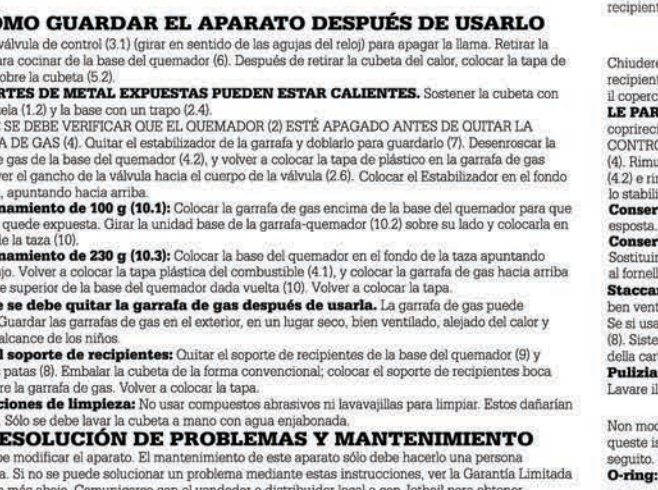
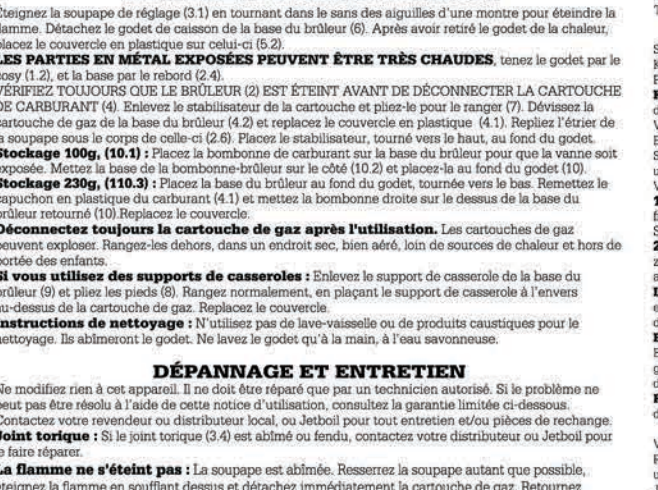
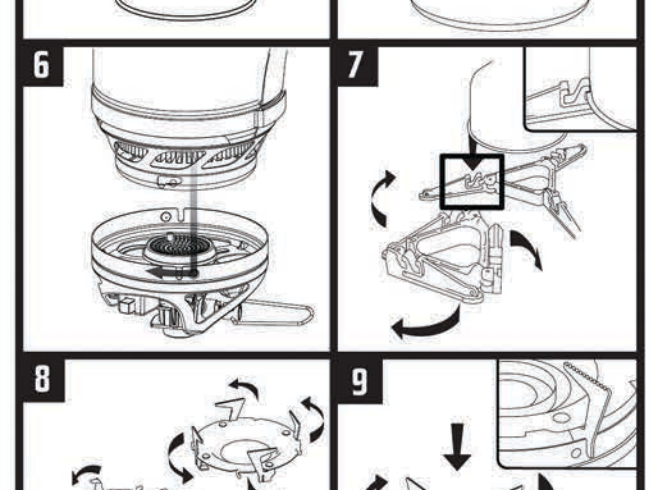
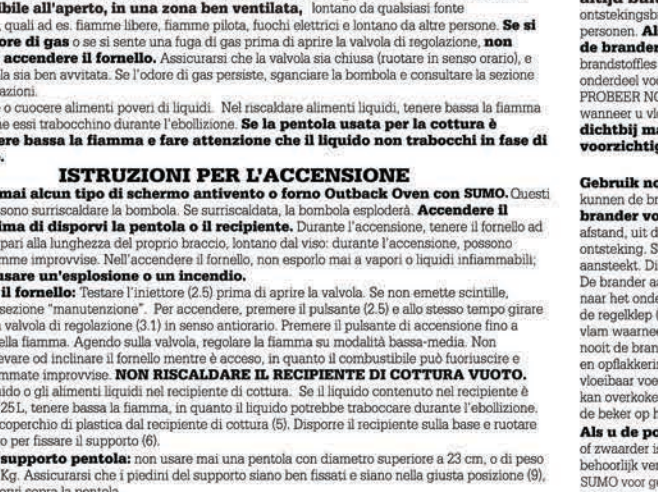
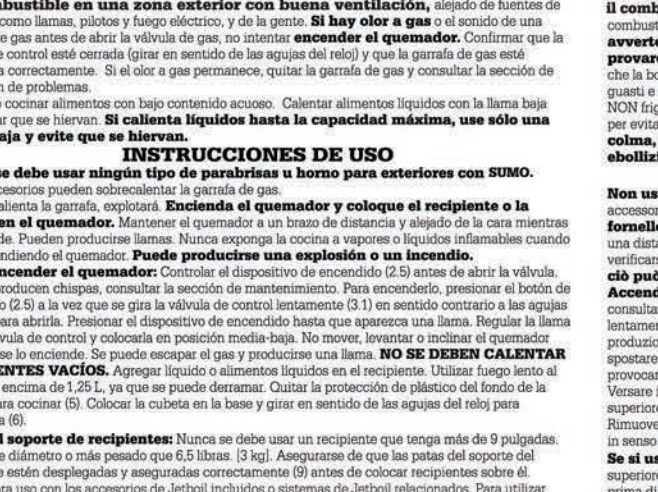
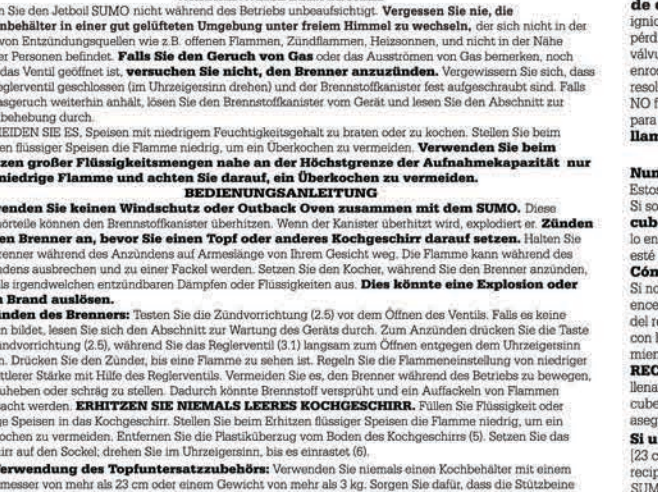
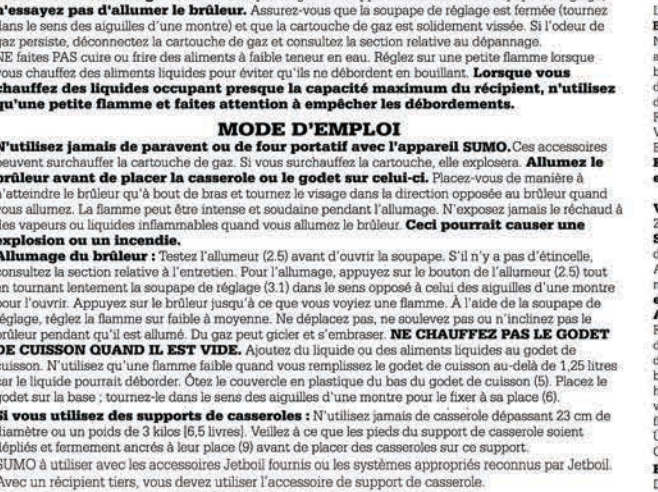
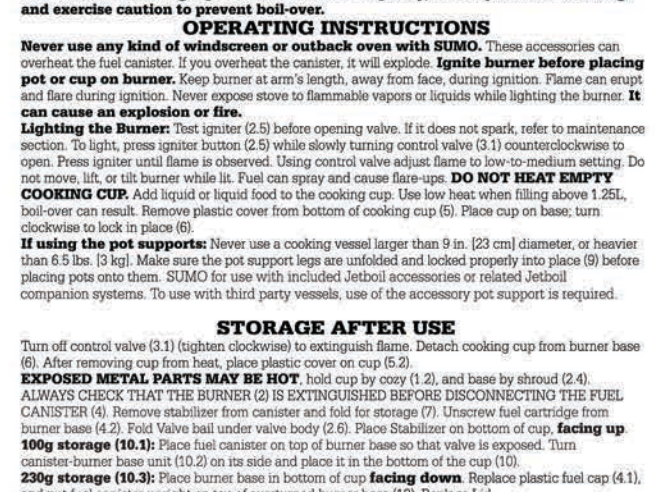
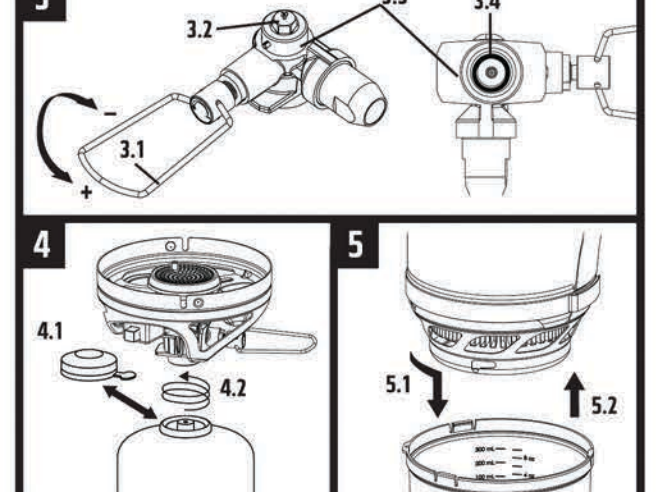
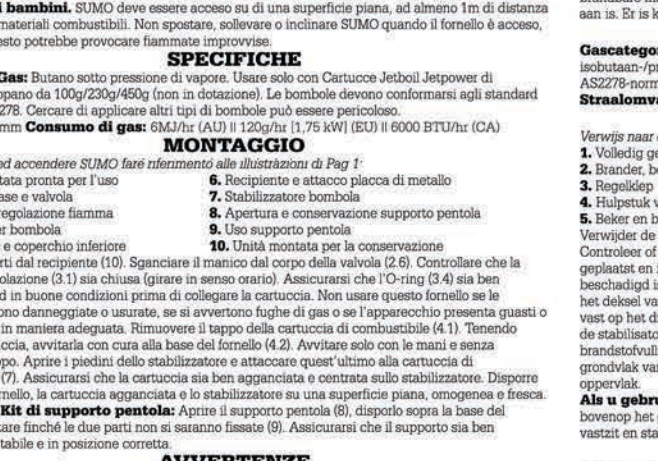
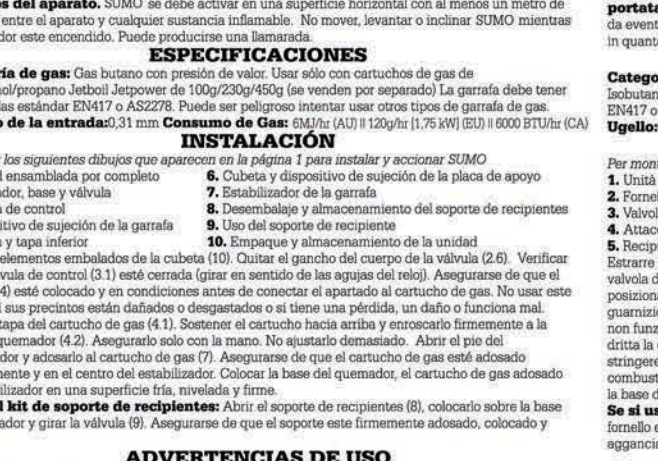
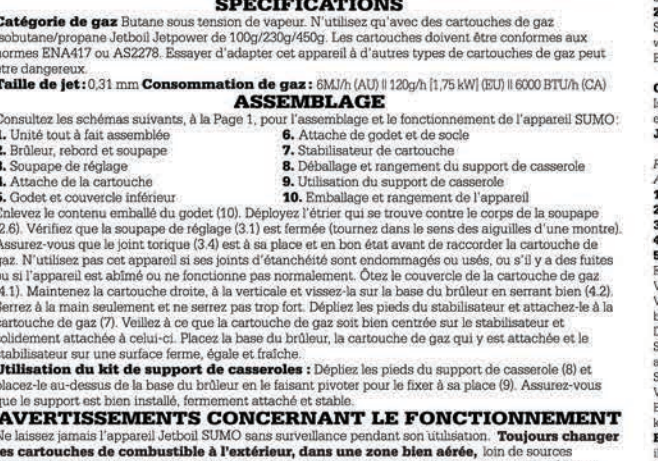
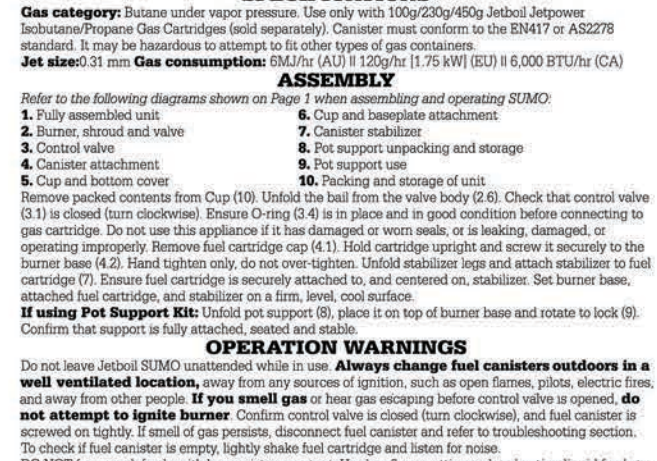
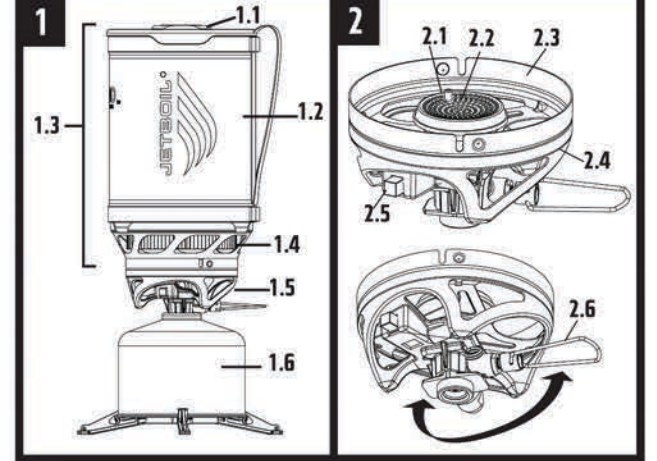

Important: Read these instructions for use carefully. Familiarize yourself with the location of the control buttons on the stove. Observe the reference use OUTDOORS only.

FOR YOUR SAFETY

If you smell gas:

- Do not attempt to light appliance.
- Do not touch any open flame.
- Disconnect from fuel supply.
- Do not store or use gasoline or any other liquids with flammable vapors in the vicinity of this or any other appliance.

CARBON MONOXIDE HAZARD

DANGER
This appliance can produce carbon monoxide which has no odor.
Never use it in an enclosed space can kill you.
Using this appliance in an enclosed space may result in carbon monoxide poisoning, coma or death.

Specifications:
Use capacity: 1.5 liter
Fuel: 1. Butane
2. Propane
3. Isobutane
4. Gas pressure: 11.5 bar
5. Gas pressure: 11.5 bar
6. Gas pressure: 11.5 bar
7. Gas pressure: 11.5 bar
8. Gas pressure: 11.5 bar
9. Gas pressure: 11.5 bar
10. Gas pressure: 11.5 bar

